

Instruction Manual

**Bi Directional DV to Analog
converter with audio level
and video color adjustments**



DV

CE

www.datavideo-tek.com

Front Panel Controls:

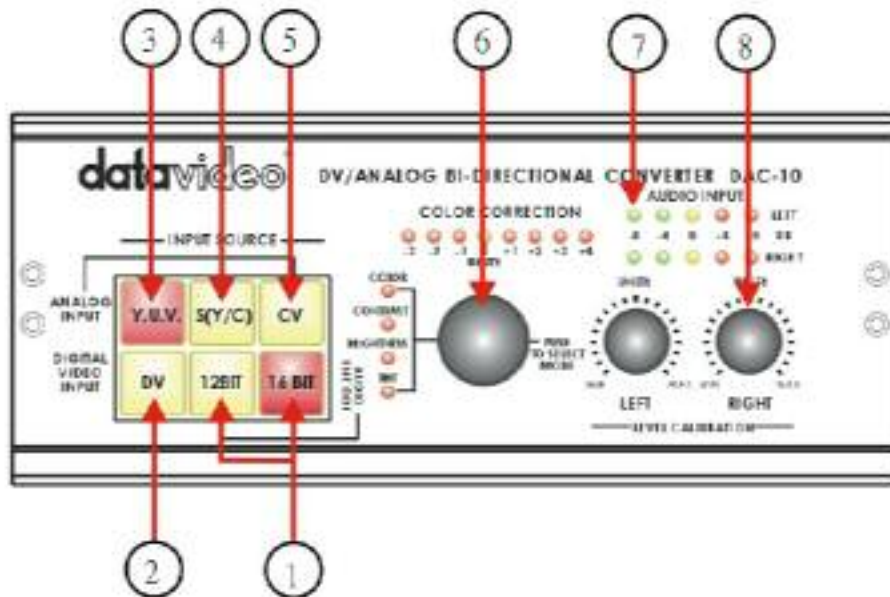

- 1. AUDIO ENCODE** Encode analog audio to DV with your choice of 12 bit/32Khz or 16bit/48Khz. 12 Bit/32khz is suggested for most DV Camcorders. 16bit/48Khz is suggested for DVD and DV Capture cards.
- 2. DV INPUT** This switch will turn red when you press it. When it is red, the **DV** input is enabled. When another input is enabled this switch will turn green.
- 3. ANALOG YUV VIDEO INPUT** This switch will turn red when you press it. When it is red, the **Analog YUV video** input is enabled. When another input is enabled this switch will turn green.
- 4. ANALOG S (Y/C) VIDEO INPUT** This switch will turn red when you press it. When it is red, the **Analog S (Y/C)** video input is enabled. When another input is enabled this switch will turn green.
- 5. ANALOG COMPOSITE VIDEO INPUT** This switch will turn red when you press it. When it is red, the **Analog Composite video** input is enabled. When another input is enabled this switch will turn green.
- 6. COLOR PROCESSOR** This control will adjust the color of both analog or DV input sources. Press the knob to select Contrast, color or tint (NTSC only). Rotate the knob to change the amount.
Note: Press the knob and hold for two seconds for resetting all adjustments back to default (unity) setting
- 7. AUDIO LEVEL INDICATORS** These meters show the audio INPUT level from the incoming source
- 8. AUDIO INPUT LEVEL CALIBRATION** Turn these knobs to adjust the Audio OUTPUT level of the DAC-10. **Adjust the audio level controls for each left (channel one) and right (channel 2) to let level LED's indicating in between yellow (0dB) and first red LED (+4dB).**

Rear Panel Connectors:

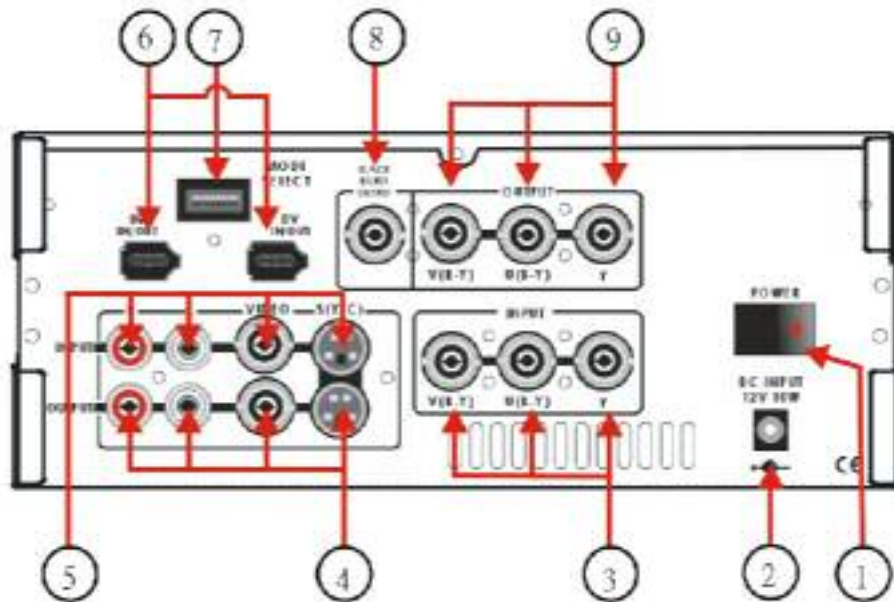

1. POWER ON/OFF SWITCH

Turns main power on or off

2. POWER INPUT JACK

Connects to the supplied 12VDC 10 watt power supply

3. COMPONENT Y.U.V. VIDEO INPUT JACKS

Input for Y.U.V. component video from Betacam, DVCPro, DVCam, some DVD players, etc.

4. AUDIO/VIDEO INPUT JACK

Analog Audio/Video input convert to DV output.

Note: You can hook up all the cables onto all video/audio input connectors at same time without conflicting to each connection

5. AUDIO/VIDEO OUTPUT JACKS

Analog Audio/Video signal output which is converted from DV input.

Note: You can hook up all the cables onto all video/audio output connectors at same time without conflicting to each connection

6. DV IN/OUT JACKS (Two)

6 pin DV (FireWire, iLink, IEEE 1394) cable, from the DV port of a camcorder, DV Bank, DV deck, etc.

7. DIP SWITCH MODE SETTING

Please refer to next page the DIP Switch setting.

8. BLACK BURST SIGNAL OUTPUT

Video Black Burst Signal to be used as a sync reference source

9. COMPONENT Y.U.V. OUTPUT JACKS

PLA Mode: Comply to SMPTE spec
 NTSC Mode: Comply to Sony Betacam spec

Dip Switch Setting for Mode Select:

* **Note1** : Mode DIP switch (**Reboot the DAC-10 if you change a DIP Switch**)

- **S1.** PAL or NTSC (PAL-ON, NTSC-OFF)
- **S2.** 7.5 IRE / 0 IRE (0 IRE-ON, 7.5 IRE-OFF). (NTSC mode only)

* **Note2:** 0 IRE is most often used in Japan. 7.5 IRE is used elsewhere.

- **S3. Locked Audio Mode**
 S3 -- OFF: Locked Audio
 S3 – ON: Unlocked Audio

- **S4 & S5 for NTSC and PAL video system**

S5	ON	S4	ON	MAC OS
			OFF	Windows 2000 and Windows 98
S5	OFF	S4	ON	Windows XP and Windows ME
			OFF	Camera

*. Please refer to next page for more detail information

- **S6.** Factory setting (OFF), please do not change.

* **Note3:** Turn-on the DAC-10 before launching any editing software.

* **Note4:** To work with a MAC with Final Cut Pro:

- 1). Select "Preferences" from Final Cut Pro menu
- 2). Select "General" page
- 3). Uncheck "Abort capture on dropped frame"
- 4). Uncheck "Abort capture on time code break" for Final cut pro 3.0
- 5). Click OK button

Dip Switch Setting to work with Windows & MAC Operation system

The DAC-10 has dip switches 4 and 5 that control the clocking frequency when it is converting video, if the dip switches are not configured for your operating system or type of device, a loss in video can occur. Please refer to dip switch chart below and make sure that your DAC-10 is setup correctly.

NTSC System (USA)
MAC OS

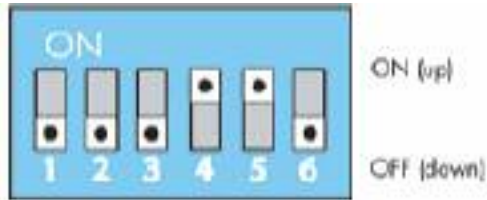

NTSC System (USA)
Windows 2000 and Windows 98

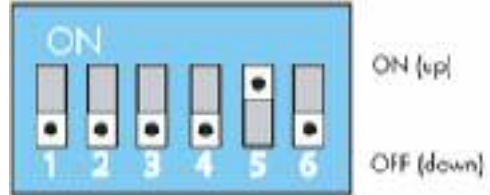

NTSC System (USA)
Windows XP and Windows ME

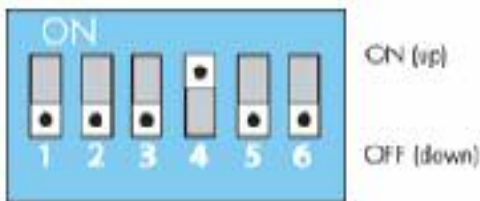

NTSC System (USA)
Camera

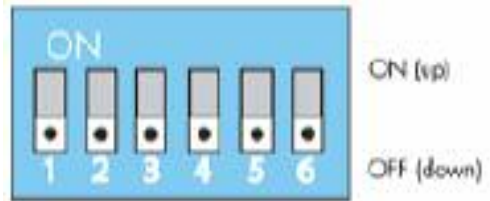

PAL System (USA)
MAC OS

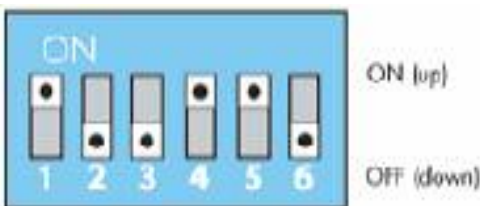

PAL System (USA)
Windows 2000 and Windows 98

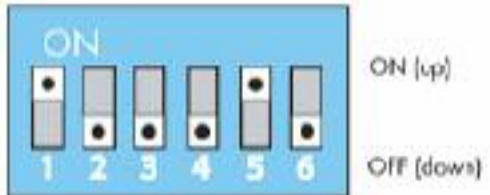

PAL System (USA)
Windows XP and Windows ME

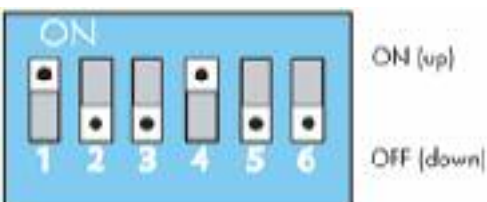

PAL System (USA)
Camera

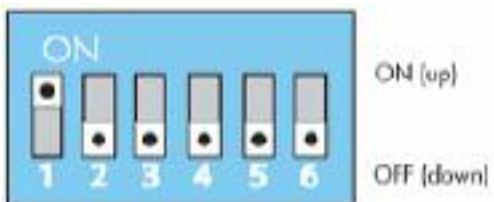

Installation Diagram

1. DV Source to Betacam In and Out

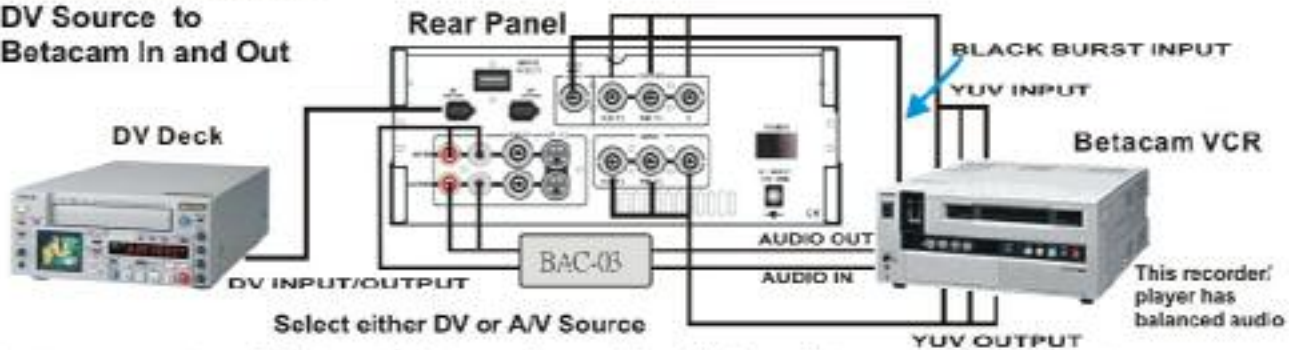

You can convert your DV tape to Betacam format for a high quality copy for broadcast purpose

2. DV Camcorder to Betacam In and Out

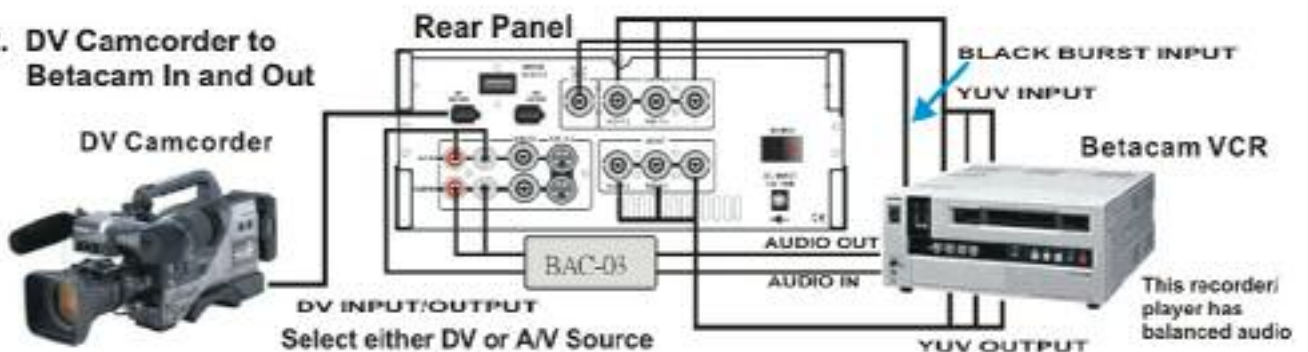

Use your DV camcorder to record your existing videos onto DV tape. Most DV camcorders can not accept analog signals. By using the DAC-1 as a converter, you can transfer your existing videotape to DV tape with no loss of quality.

3. S(Y/C) or Composite Video In to Component Out

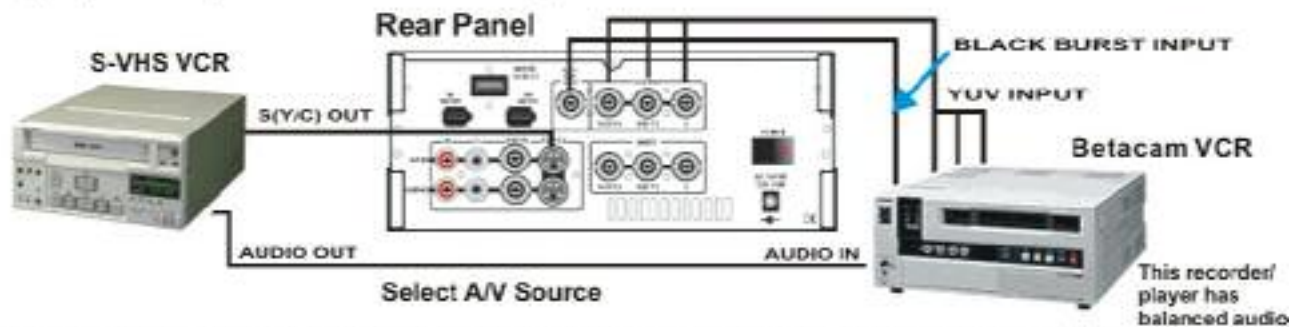

You can convert your S-VHS tape to Betacam format for a high quality copy for broadcast purpose

4. PC/MAC to or from Betacam

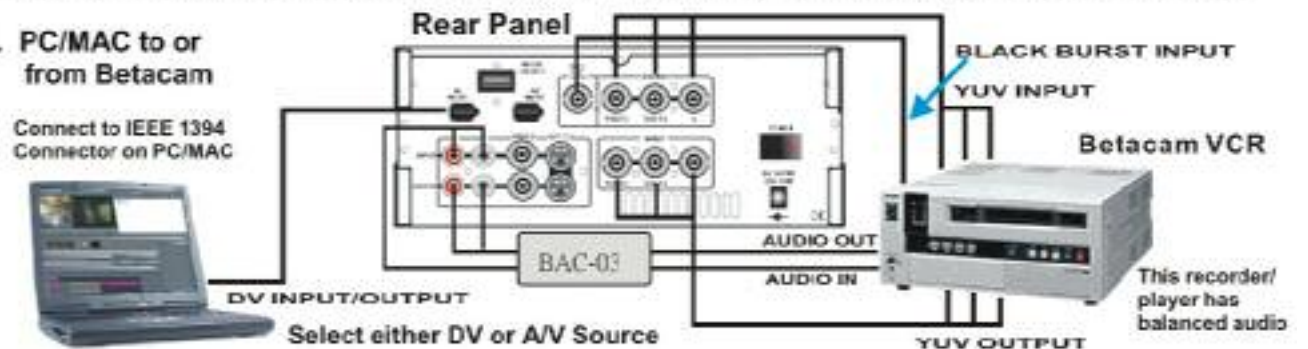

Now you can import or export directly between a Betacam deck and your PC or MAC with a DV card and editing software

Note: If you are converting between balanced audio and unbalanced audio we suggest that you use a

Operation Procedure:

Step_1. Select the desired mode by setting the dip switches. Reboot the DAC-10 after changing the dip switches

Step_2. Install the equipment as shown in installation diagrams

Step_3. Ensure that all equipment is turned on

Step_4. Select the video source. If the video source is analog, select the desired audio sampling Rate

Step_5. Playback the source video

Step_6. If needed, calibrate the playback video and audio output level

Step_7. To generate an analog Color Bar output, under the DV mode, press on the "16 BIT" key. The Color Bar will output from YUV,S(Y/C) and Composite video jacks at the same time. Press on the "16 BIT" key again back to normal operation.

INPUTS

S-VHS Video Source
Composite Video Sources
Component YUV Video
DV (iLink)Source

SPECIFICATION

Y/C in: 4-pin 75 ohm DIN connector
 1.0 Vp-p 75 ohm BNC connector
 Betacam standard, Y, R-Y, B-y 75 ohm BNC connectors
 Data Transfer Rate 25Mbps,
 PAL: 4:2:0 NTSC: 4:1:1

Outputs

S-VHS Video Source
Composite Video Source
Component YUV Video
Black Burst Video

Y/C out 4-pin 75 ohm DIN connector
 1.0 Vp-p 75 ohm BNC connector
 Betacam standard, Y, R-Y, B-y 75 ohm BNC connectors
 75 ohm BNC connector

Video Frequency Response
(DV input)

5.0 MHz +/- 3 dB

Differential Gain

+/- 3 %

Differential Phase

< 3

Video S/N Ratio

Decoder (DV In)

> 50 dB

Encoder (A/V In)

> 48 dB

Audio Sampling Rate

12 bit/32KHz and 16bit/48KHz optional

Audio Level

Unity +/- 1.0dB

Audio THD

< 0.5%

Audio Frequency Response

20 ~ 20KHz +/- 3dB

Audio S/N Ratio

> 65dB

GENERAL

Power Input

DC 12V 1.0A AC Adaptor (included)

Ambient Temperature

32[°] ~ 130[°] F (0[°] ~ 55[°] C)

Ambient Humidity

Less than 90 %

Dimensions

210 (W) x 240 (D) x 88(H) mm (without rubber feet)
 8.3"(W) x 9.45"(D) x 3.5" (H) (without rubber feet)

Weight

1.8 Kg/4.0lbs

Accessories

BNC, S-Video and DV cables (included)

Service and Support

It is our goal to make your products ownership a satisfying experience. Our supporting staff is available to assist you in setting up and operating your system. Please refer to our web site www.datavideo-tek.com for answers to common questions, support requests or contact your local office below.

Datavideo Corporation (USA)

12300-U East Washington Blvd., Whittier, CA 90606 USA

Tel: +1 562 696 2324 www.datavideo.us

Datavideo Technologies Europe BV

Californiedreef 263565 BL Utrecht, The Netherlands

Tel: +31 30 261 9656 www.datavideo.info

Datavideo UK Limited

Unit 2 Waterside Business Park, Hadfield, Glossop, Derbyshire SK131BE UK

Tel: +44 1457 851000 www.datavideo.info

Datavideo Technologies Co., Ltd.

10F, 176 Jian-Yi Rd, Chung Ho City, Taipei Hsien, Taiwan 235

Tel: +886 2 8227 2888 www.datavideo.com.tw

Datavideo Technologies China Co.

2F-D, 2 Lane 777, West Guangzhong Rd, Zhabei District, Shanghai, China

Tel: +86 21 5603 6599 www.datavideo.cn

Datavideo Technologies (S) PTE Ltd.

100 Lor 23, Geylang Rd, #01-03 D'Centennial, Singapore 388398

Tel: +65 6749 6866 www.datavideo.sg

